

BT32

Our micro-sized Bluetooth module is one of the smallest form factors available. The BT32 is designed for maximum performance in a minimal space and includes 5 general purpose input/output lines, several serial interface options, analog-to-digital input, and up to 1.5Mbps data throughput. Other popular Bluetooth profiles, such as OBEX and DUN, are also available.



10.4mm x 13.5mm

Features

Bluetooth features

- FCC & Bluetooth licensed radio
- Bluetooth v3.0
- Class 1.5 radio
- Range up to 20m LOS
- 1.5Mbps data throughput
- 128-bit encryption security
- Multipoint capability up to 7 slaves
- FM Tx/Rx integrated radio

Hardware configuration

- Cortex-M3 microprocessor up to 72MHz
- 256K bytes flash memory
- 48K bytes RAM memory
- UART, up to 2Mbps
- SPI and I2C interfaces
- 5 general purpose I/O
- 4x12bit A/D inputs
- 1 DAC output
- 1 LPO input

Embedded software

- Amp'edUP Bluetooth stack (SPP, OBEX, A2DP, HEP)
- abSerial, AT command set
- SDK, Software Development Kit (Optional)
- BlueGuard, data encryption software (Optional)
- Mobile application software(Optional)

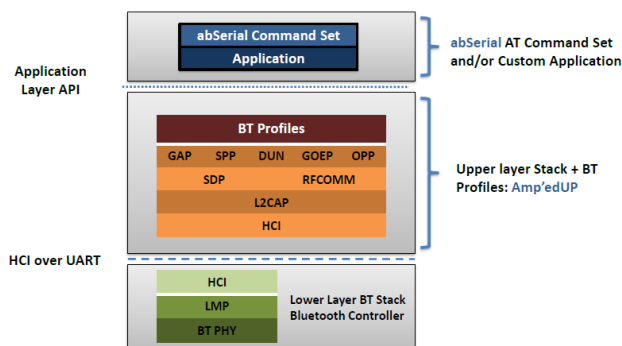
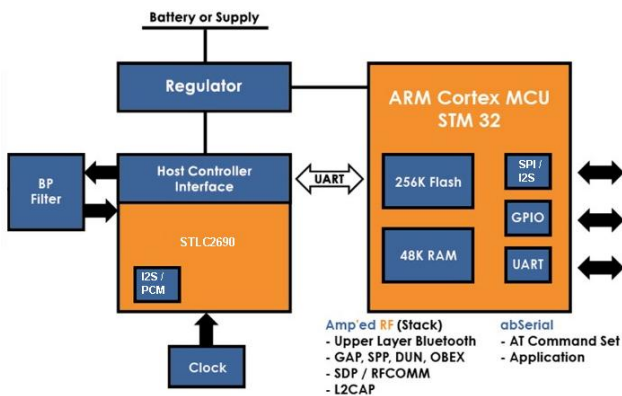

Amp'ed RF Technology Bluetooth

We've teamed up with ST Microelectronics and ST Ericsson to offer you the most advanced Bluetooth technology in a variety of highly reliable and affordable platforms. Our Bluetooth Upper Layer Stack, Amp'ed UP, and AT command serial interface, abSerial, give you options ranging from complete turnkey solutions to licensing our designs and firmware – options our competitors simply don't have.

